

Powerex, Inc., 200 Hillis Street, Youngwood, Pennsylvania 15697-1800 (412) 925-7272
 Powerex, Europe, S.A. 428 Avenue G. Durand, BP107, 72003 Le Mans, France (43) 41.14.14

Phase Control SCR
 1800 Amperes Average
 2200 Volts

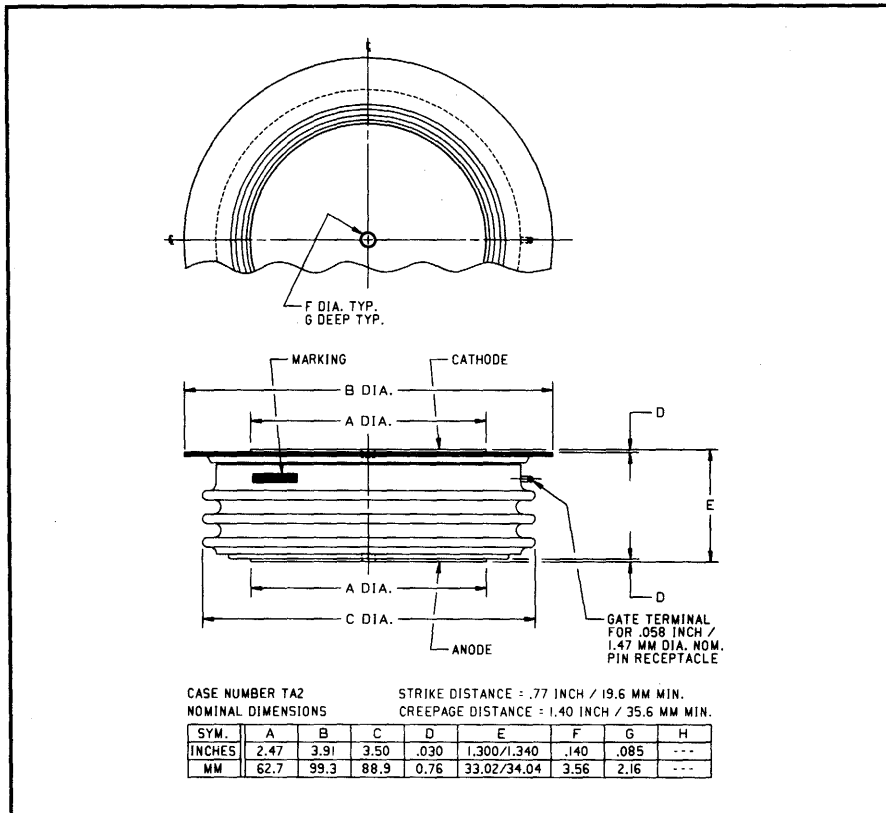

TA20 1800A (Outline Drawing)

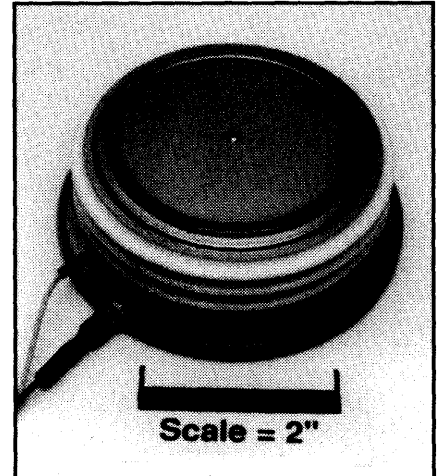

TA20 1800A Phase Control SCR
 1800 Amperes Average, 2200 Volts

Ordering Information:

Select the complete 12 digit part number you desire from the table below.

Type	Voltage	Current	Turn-off	Gate Current	Lead Code
	V_{DRM}/V_{RRM} (Volts)	$I_{T(av)}$ (A)	t_q (μ sec)	I_{GT} (mA)	
TA20	02 through 22	18	0	3	DH
	200V through 2200V	1800A	250 μ sec (Typical)	200mA	12"

Description:

Powerex Silicon Controlled Rectifiers (SCR) are designed for phase control applications. These are all-diffused, Press-Pak, hermetic Pow-R-Disc devices employing the field proven amplifying gate.

Features:

- Low On-State Voltage
- High di/dt Capability
- High dv/dt Capability
- Hermetic Packaging
- Excellent Surge I^2t Ratings

Applications:

- Power Supplies
- Motor Control



Powerex, Inc., 200 Hillis Street, Youngwood, Pennsylvania 15697-1800 (412) 925-7272
Powerex, Europe, S.A. 428 Avenue G. Durand, BP107, 72003 Le Mans, France (43) 41.14.14

TA20 1800A
Phase Control SCR
1800 Amperes Average, 2200 Volts

Absolute Maximum Ratings

Characteristics	Symbol	TA20 1800A	Units
Non-repetitive Transient Peak Reverse Voltage	V_{RSM}	$V_{RRM} + 100V$	Volts
RMS On-state Current, $T_C = 85^\circ C$	$I_{T(rms)}$	2820	Amperes
Average Current 180° Sine Wave, $T_C = 85^\circ C$	$I_{T(av)}$	1800	Amperes
RMS On-state Current, $T_C = 55^\circ C$	$I_{T(rms)}$	4200	Amperes
Average Current 180° Sine Wave, $T_C = 55^\circ C$	$I_{T(av)}$	2675	Amperes
Peak One Cycle Surge On-state Current (Non-repetitive) 60Hz	I_{tsm}	40000	Amperes
Peak One Cycle Surge On-state Current (Non-repetitive) 50Hz	I_{tsm}	36500	Amperes
Critical Rate-of-rise of On-state Current (Non-repetitive)	di/dt	400	A/ μ sec
Critical Rate-of-rise of On-state Current (Repetitive)	di/dt	150	A/ μ sec
I^2t (for Fusing) for One Cycle, 60Hz	I^2t	6.67×10^6	A ² sec
Peak Gate Power Dissipation	P_{GM}	16	Watts
Average Gate Power Dissipation	$P_{G(av)}$	3	Watts
Operating Temperature	T_j	-40 to +125°C	°C
Storage Temperature	T_{stg}	-40 to +150°C	°C
Approximate Weight		2.1	lb.
		950	g
Mounting Force		9000 to 11000	lb.
		4100 to 5000	kg.



Powerex, Inc., 200 Hillis Street, Youngwood, Pennsylvania 15697-1800 (412) 925-7272
 Powerex, Europe, S.A. 428 Avenue G. Durand, BP107, 72003 Le Mans, France (43) 41.14.14

TA20 1800A
 Phase Control SCR
 1800 Amperes Average, 2200 Volts

Electrical Characteristics, T_j = 25°C Unless Otherwise Specified

Characteristics	Symbol	Test Conditions	Min.	Typ.	Max.	Units
Repetitive Peak Reverse Leakage Current	I _{RRM}	T _j = 125°C, V _R = V _{RRM}			100	mA
Repetitive Peak Forward Leakage Current	I _{DRM}	T _j = 125°C, V _D = V _{DRM}			100	mA
Peak On-state Voltage	V _{TM}	I _{TM} = 3000A Peak Duty Cycle < 0.1%			1.45	Volts
Threshold Voltage, Low-level	V _{(TO)1}	T _j = 125°C, I = 15%, I _{T(av)} to πI _{T(av)}			0.71870	Volts
Slope Resistance, Low-level	r _{T1}				0.1669	mΩ
Threshold Voltage, High-level	V _{(TO)2}	T _j = 125°C, I = πI _{T(av)} to I _{TSM}			0.97647	Volts
Slope Resistance, High-level	r _{T2}				0.1215	mΩ
V _{TM} Coefficients, Low-level		T _j = 125°C, I = 15% I _{T(av)} to πI _{T(av)}				A ₁ = 1.0791 B ₁ = -0.12551 C ₁ = 3.874E-06 D ₁ = 0.02151
V _{TM} Coefficients, High-level		T _j = 125°C, I = πI _{T(av)} to I _{TSM}				A ₂ = -6.7846 B ₂ = 1.1619 C ₂ = 1.858E-04 D ₂ = -0.03560
Typical Turn-on Time	t _{on}	I _T = 1000A, V _D = 1500V		4		μsec
Typical Turn-off Time	t _q	T _j = 125°C, I _T = 250A, di _R /dt = 50A/μsec Reapplied dv/dt = 20V/μsec Linear to 80% V _{DRM}		250		μsec
Minimum Critical dv/dt - Exponential to V _{DRM}	dv/dt	T _j = 125°C	300			V/μsec
Gate Trigger Current	I _{GT}	T _j = 25°C, V _D = 12V			200	mA
Gate Trigger Voltage	V _{GT}	T _j = 25°C, V _D = 12V			3.0	Volts
Non-Triggering Gate Voltage	V _{GDM}	T _j = 125°C, V _D = V _{DRM}			0.15	Volts
Peak Forward Gate Current	I _{GTM}				4	A
Peak Reverse Gate Voltage	V _{GRM}				5	Volts

Thermal Characteristics

Maximum Thermal Resistance, Double Sided Cooling

Junction-to-Case	R _{θ(j-c)}	0.015	°C/W
Case-to-Sink	R _{θ(c-s)}	0.007	°C/W



Powerex, Inc., 200 Hillis Street, Youngwood, Pennsylvania 15697-1800 (412) 925-7272
 Powerex, Europe, S.A. 428 Avenue G. Durand, BP107, 72003 Le Mans, France (43) 41.14.14

TA20 1800A
 Phase Control SCR
 1800 Amperes Average, 2200 Volts

Maximum On-State Forward Voltage Drop
 (T_J = 125 °C)

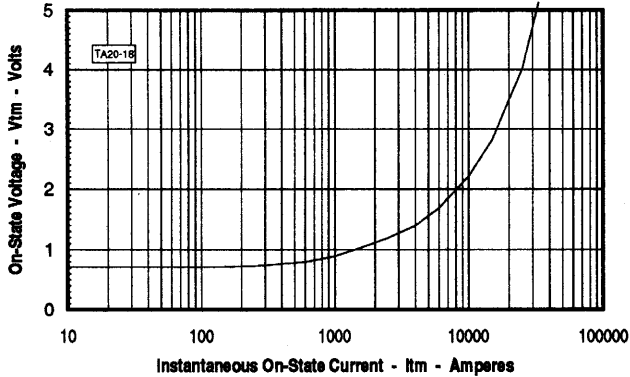

Maximum Transient Thermal Impedance
 (Junction to Case)

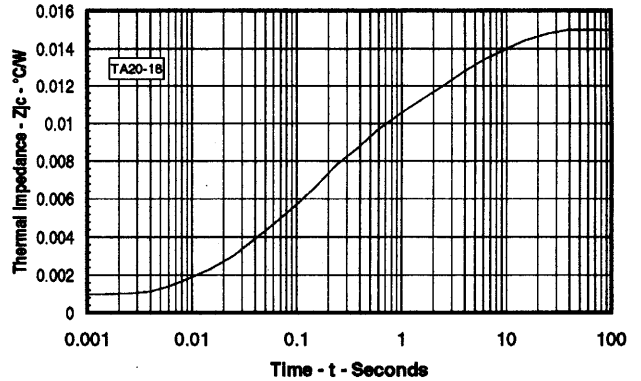

Maximum On-State Power Dissipation
 (Sinusoidal Waveform)

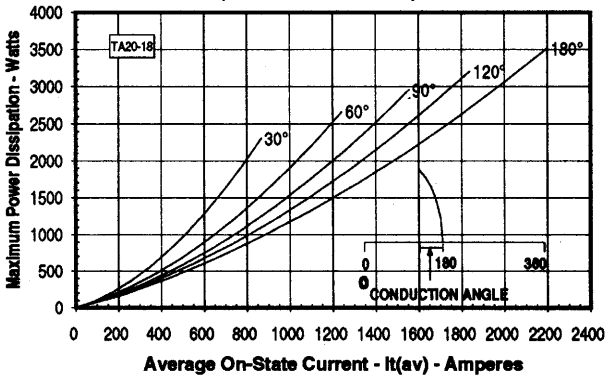

Maximum Allowable Case Temperature
 (Sinusoidal Waveform)

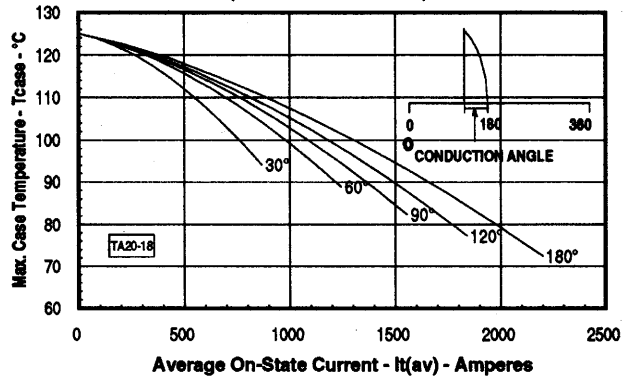

Maximum On-State Power Dissipation
 (Rectangular Waveform)

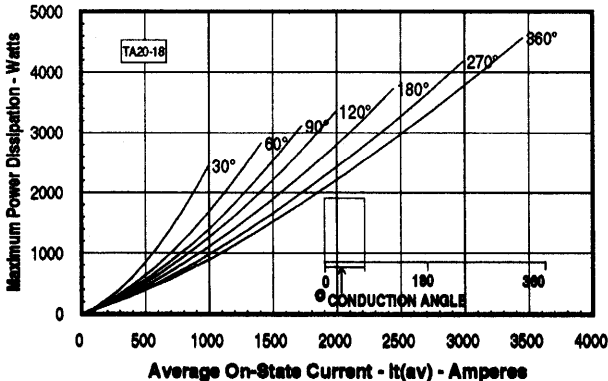

Maximum Allowable Case Temperature
 (Rectangular Waveform)

